

Quality requirements for corrugated cardboard products

1. Wave Height:

2/3-layer E wave	1.0 – 1.8 mm
2-layer F wave	0.6 – 1.4 mm
4/5-layer FE wave	2.0 – 2.9 mm
2/3-layer B wave	2.2 – 3.0 mm
3-layer C wave	3.2 – 4.0 mm
5-layer BC wave	6.1 – 6.9 mm
4/5-layer BE wave	3.8 – 4.7 mm

2. The flatness of sheets after laminating:

A deviation from flatness of 5% of the sheet length is allowed.

The ratio of the height of the bend to the length of the side on which the bend occurs.

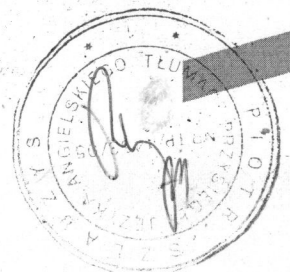
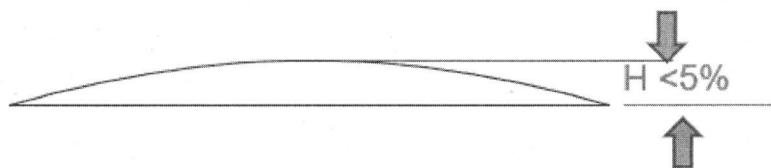

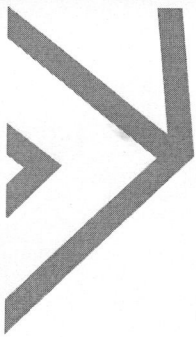

3. Tolerance of internal dimensions:

Format length:

up to 100 mm	± 1mm
from 100 to 379 mm	±2mm
from 380 to 570 mm	±3mm
from 571 to 759 mm	± 4mm
from 760 to 1140 mm	± 5mm

4. The flap gap after folding the package, the so-called Fishtail (V) (max. difference between dimensions K1 and K2) and lack of parallelism between the joining edges at the glue flap:

Box height H	3 B/C k1 – k2	5BC/5BE/5EE k1 – k2	2/3E /2B k1 – k2
up to 400 mm	± 4mm	± 4.5mm	±2.5 – 3.5mm
above 400 mm below 700 mm	± 5.0mm	± 5.5mm	±4.5mm
above 700 mm	±8.0mm	± 8.5mm	±5.5mm

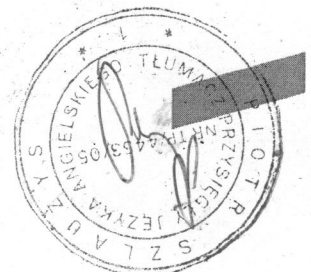
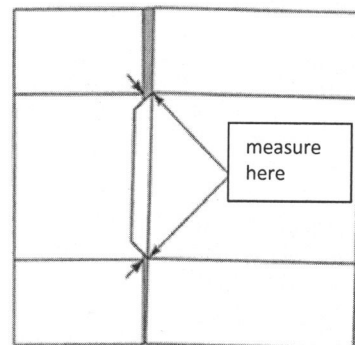
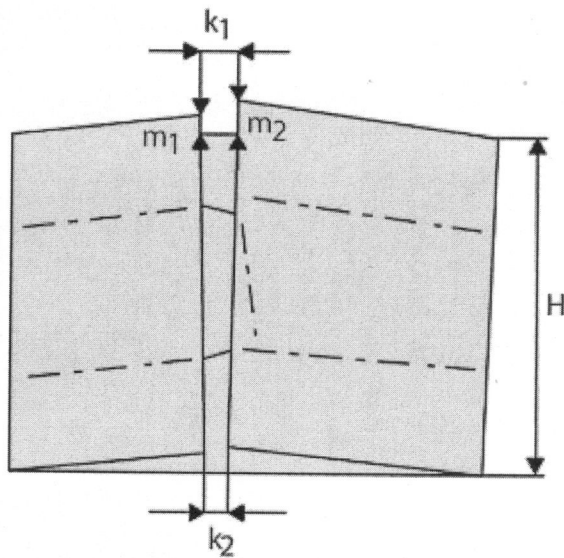

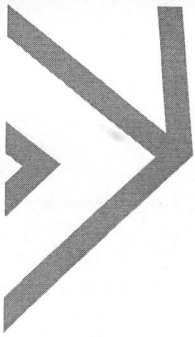

5. Parallel glueing

Shifting the parallelism of glueing the packaging in relation to two opposite but connecting parts

All types of glued packaging made of 3- and 5-layer cardboard.
Tolerance ± 3 mm

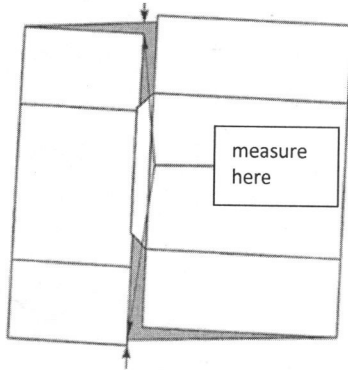

6. Deviation of the gap width at the gluing (c):

Cardboard	B	C	E	B/C
Acceptable level of defects in delivery	3%	3%	3%	3%
Maximum deviation between boxes. The average of C dimensions measured on the crease line	± 4 mm	± 4.0 mm	± 2.0 mm	± 4.5 mm

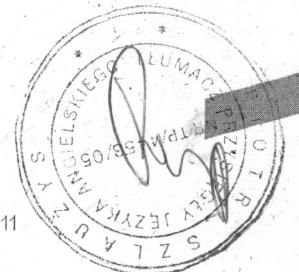
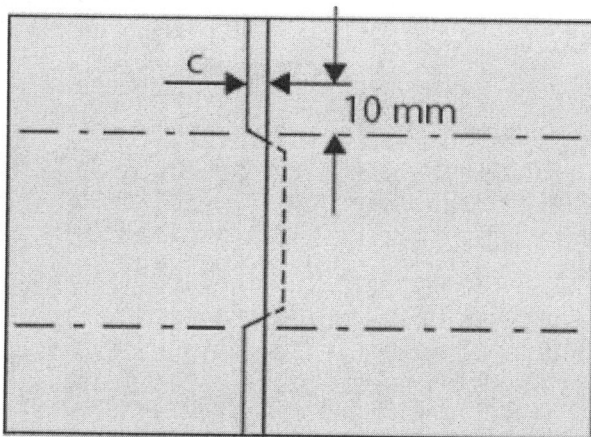

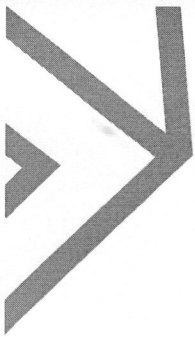

7. Absolute humidity:

The optimal moisture content of cardboard is 6%-9%.

8. Basis weight

Page | 4

Weight of 1 m² of corrugated cardboard surface in g/m². Tolerance of basis weight \pm 5%.

9. Offset printing and colours

Colour deviations from the pattern approved by the customer in accordance with the ISO 12647-2 standard are allowed.

In the case of GD wastepaper cartons, it should be taken into account that colour deviations are caused by a different shade of white of the sheets in each batch of cardboard. Therefore, we recommend visiting the first print.

10. Print matching

The tolerance between the print and the cutout in relation to the leading edge is \pm 3-5mm, depending on the quality of the materials used for production and the cardboard type.

I, the undersigned, Piotr Szlaużys, a sworn translator of English and Polish since 2001, appointed by the Polish Ministry of Justice and registered in the Sworn Translators Official Register No. TP/4453/05, hereby certify that the foregoing English text is a true and faithful translation of the document submitted to me. Augustów, Poland, 23 April 2024. Repertory No. 847/24.

